



Oikia

Fodelia Retail Oy Finland

Oikia

MEANS REAL

Oikia is the only, genuinely Finnish snacks and baby food manufacturer in mainland Finland

Our location in Northern Ostrobothnia under the midnight sun offers us unbeatable natural advantages:

The purity of the Finnish raw materials is a known fact, but potatoes and oats grown at 65° during the intense summer light carry a special aroma.



OIKIA THE SNACKS AND BABY FOOD FROM FINLAND

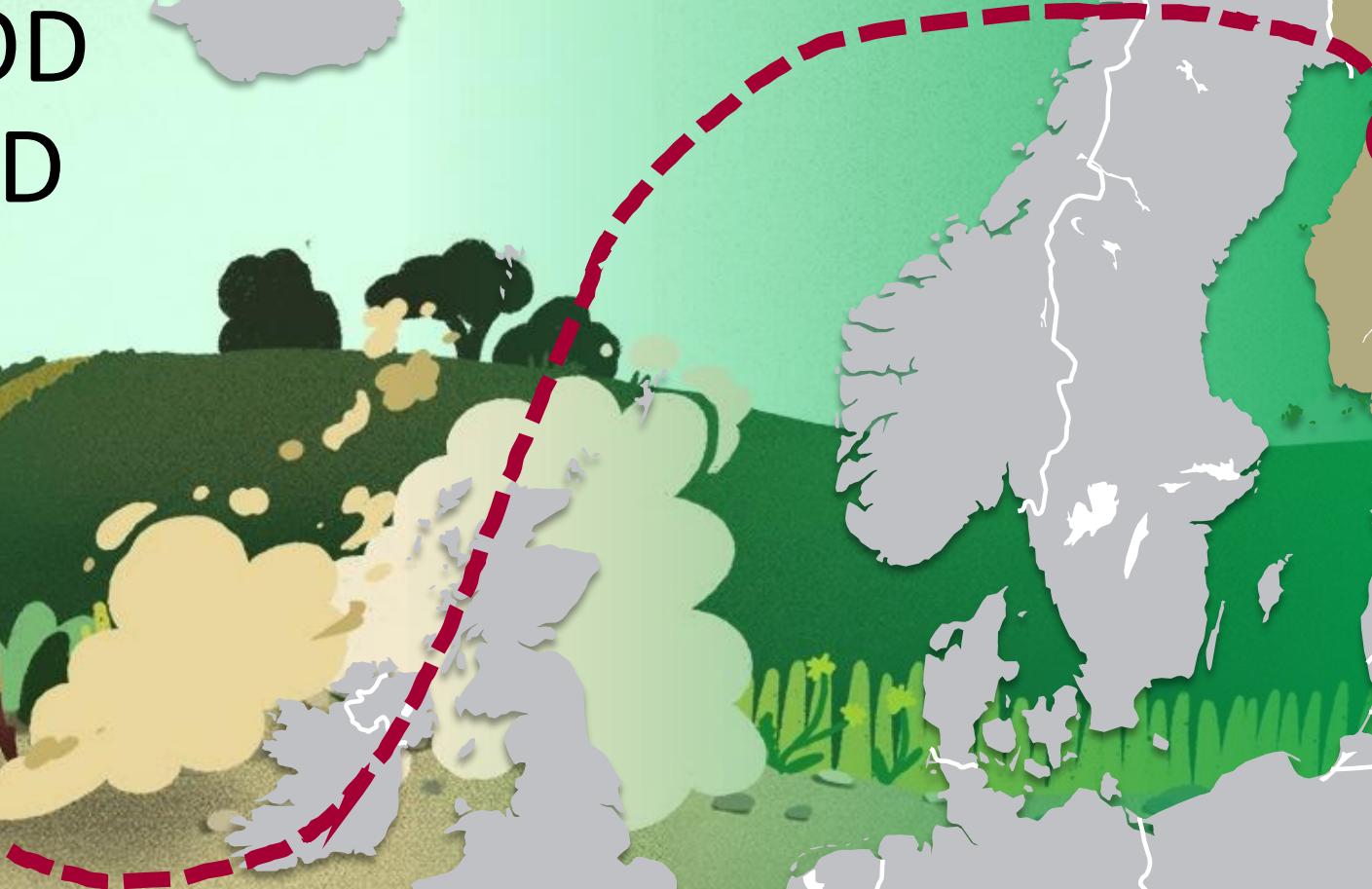

PYHÄNTÄ

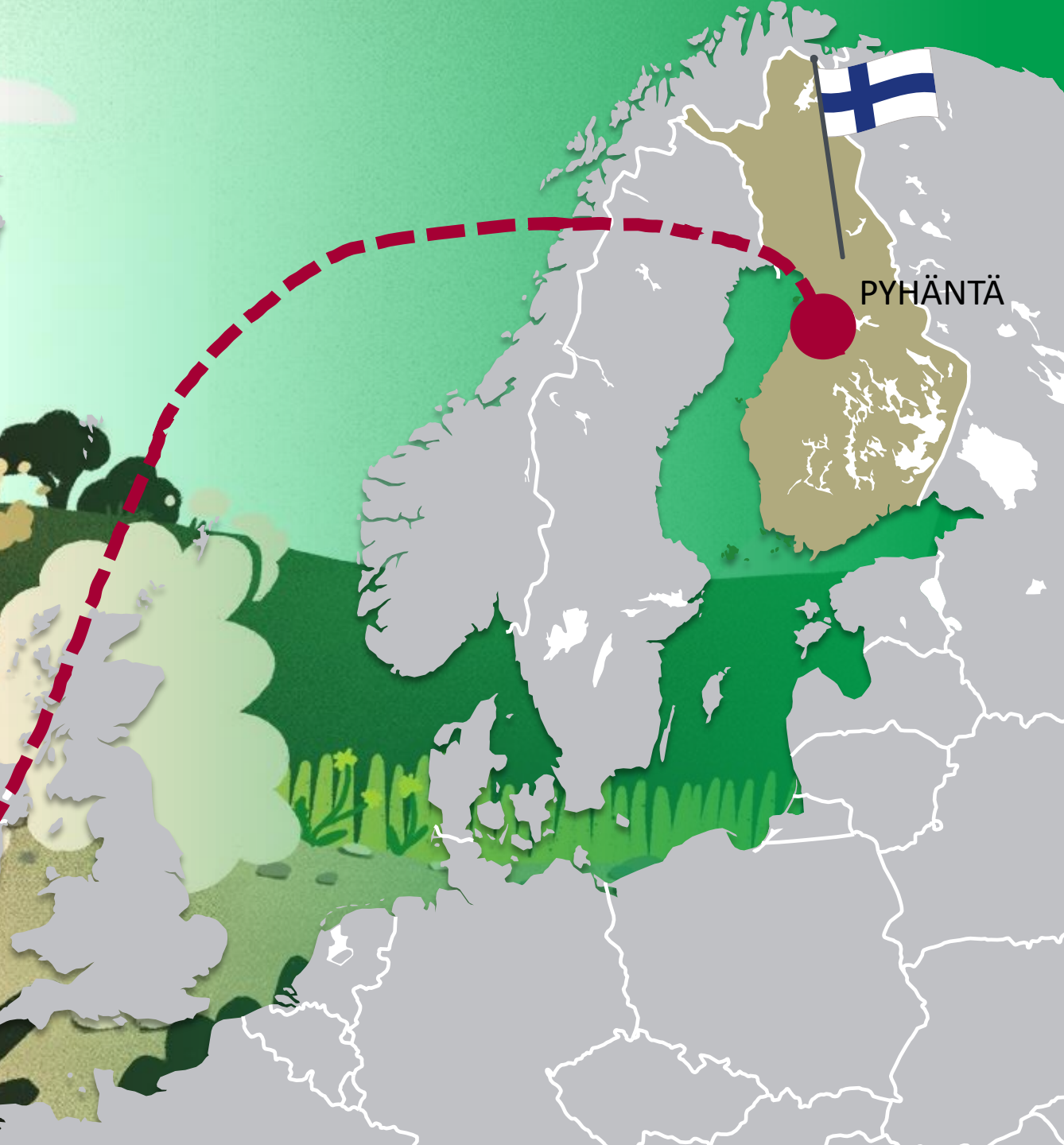

OATIS

OATIS –launch, the first extruded gluten-free oat snack in the market

Oikia

Sainsbury's listed Oatis in 300+ stores
Oikia –brand launched

BRC Food Safety Certificate

Pyhännän Einestuoatanto established to create jobs for women.

Real Snacks Oy established, when Raisio liquidates the business.

Exports started

1979

1984

2001

2005

2010

2015

2017

2018

2019

2021

2023

Raisio Oy acquires Pyhännän Einestuoatanto and the company reaches almost 30% market share in Finland

Real Snacks –brand launched in Finland

First CEO from outside of the company

New extrusion line

Automation of the packing line



SUSTAINABILITY FROM THE GET GO

Oikia has been sustainable from the very beginning of its history. The manufacturing of potato chips was initiated to create jobs for women. At that time Pyhântä area relied heavily on timber industry employing mainly men

- Social responsibility
- Domestic raw materials
- Domestic production
- High proportion of local materials
- Short distance in transportation



SUSTAINABILITY IN PRODUCTION

Sustainability is an essential feature throughout the production process. Our potato chip and oats snack packages are carton recyclable. They are printed by using greener EGP printing method. We use renewable energy, the production process is run by local power plant using wood chips. The potato peels are not just thrown to biowaste, but used as animal feed by local farmers.

- Carton recyclable packaging (potato&oats)
- Greener printing (EGP) 30% less printing colours
- Potatoes from High Grade area = Minimum amount of pesticides
- Energy from domestic wood chips
- Potato peels utilized as animal feed
- CO2 footprint calculated per SKU

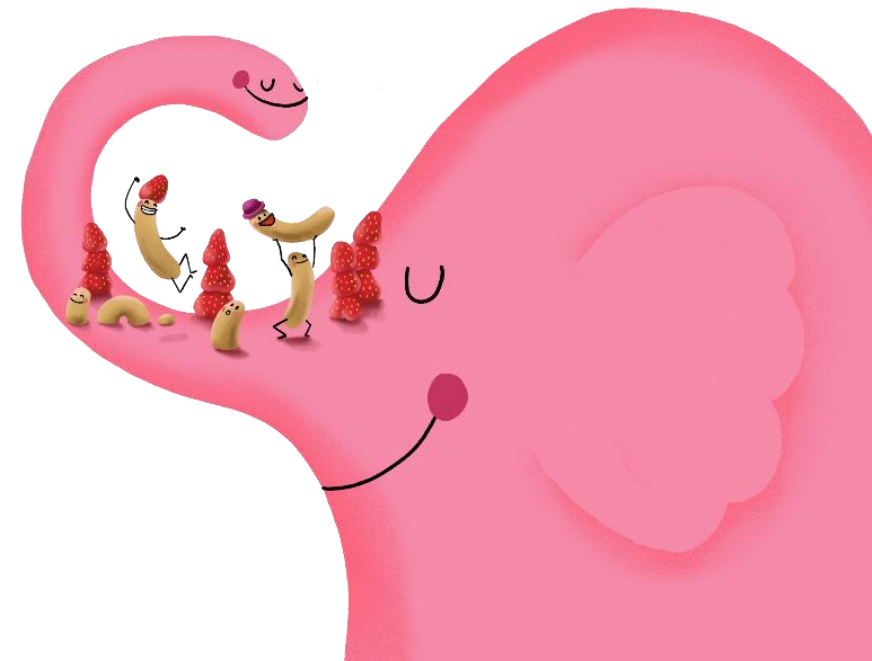

Aside from sustainable production, we also, genuinely, take care of our personnel and customers.

To support our already large selection of vegan products, all of our new products will be vegan. We also use less salt in our products, which makes Oikia the perfect brand for the increasingly informed customers.

On top of all that, all of our products are also gluten free.

- Wide range of vegan products
- Kids products always organic
- Factory gluten free
- All upcoming products will be vegan
- Less salt
- Committed personnel
- Reward system for all of our employees

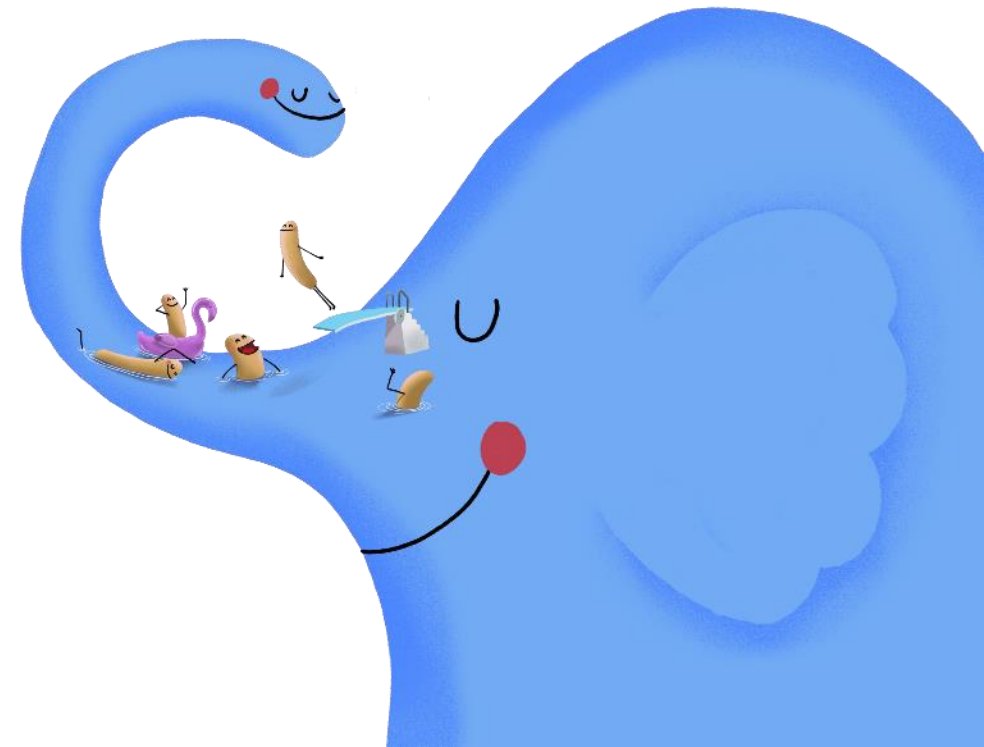

PRODUCT GROUPS

Oikia



POTATO CHIPS



OAT SNACKS



BABY FOOD

POTATO CHIP RANGE – WITH OR WITHOUT RIBBLES

- SALTED
- SOUR CREAM & ONION
- CHILI
- PAPRIKA
- WHITE ONION
- GRILLS
- SALT & VINEGAR
- VEGAN
- ANY FLAVOUR YOU WISH FOR

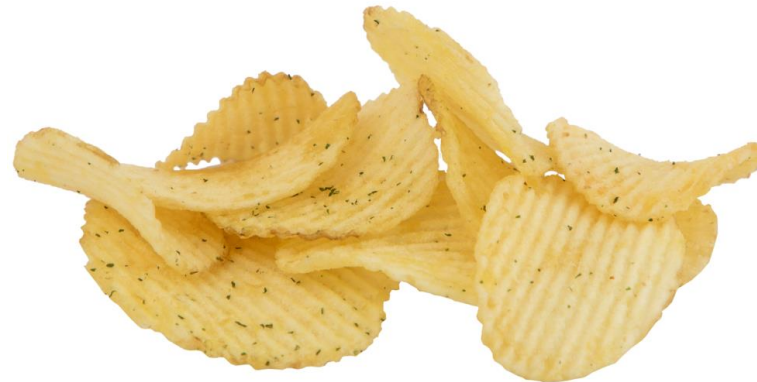

KETTLE POTATO CHIP RANGE – WITH POTATO SKIN ON

- SALTED
- SOUR CREAM & ONION
- CHILI
- PAPRIKA
- WHITE ONION
- GRILLS
- SALT & VINEGAR
- ANY FLAVOUR YOU WISH FOR



PELLET SNACKS – VEGETABLE OIL FRYING

- LENTIL SNACKS
- POTATO SNACKS
- FABA BEAN SNACKS
- VEGETABLE SNACKS
- ANY FLAVOUR YOU WISH FOR

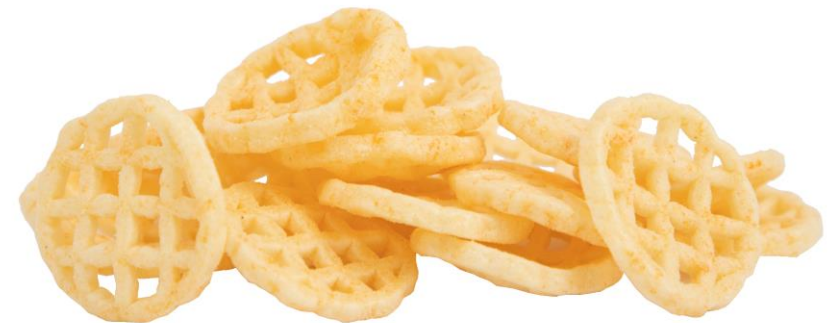

SNACKS IN MANY FORMS – POTATOS, OATS AND CORN

Crispy snacks are a treat to us and many others – and they truly are delicious. The craving for crispy treats may strike even if, for some reason, one is careful of their diet. Therefore, we choose not to stand idly by as health conscious customers have to go on with their lives totally deprived of salty snacks.

Dikia

The idea of totally a new snack started after 2010 and in 2017 our innovative oat snack, Oatis was launched. They are the little bit healthier option for the informed customer as they surrender to their craving for some salty treats – and who are we to deny that from anyone.

OATIS

OAT SNACKS RANGE - EXTRUSION, VEGETABLE OIL FRYING

- JALAPENO-RANCH
- ORGANIC
- VEGAN CHEESE DOODLES
- SEA SALT
- ITALIAN CHEESE STYLE
- MEDITERRANEAN HERBS
- ANY FLAVOUR YOU WISH FOR



PUFFED SNACKS - EXTRUSION WITH SEASONING

- CHEESE SNACKS
- CORN SNACKS
- OAT SNACKS
- ANY FLAVOUR YOU WISH FOR
- ORGANIC



CORN SNACKS FOR CHILDREN - EXTRUSION

- ORGANIC
- STRAWBERRY
- ORIGINAL
- BANANA
- ANY FLAVOUR YOU WISH FOR



PACKAGING SIZE AND SALES LOT OPTIONS

SNACKS:

- 50G / 28 CU
- 100G / 14 CU
- 200G / 16 CU
- 220G / 16 CU
- 225G / 16 CU
- 250G / 16 CU
- 275G / 15 CU
- 300G / 15 CU
- 350G / 12 CU

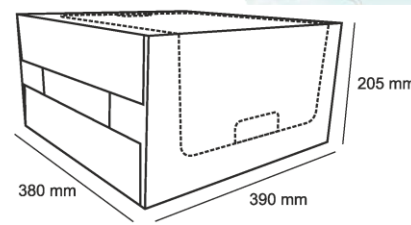
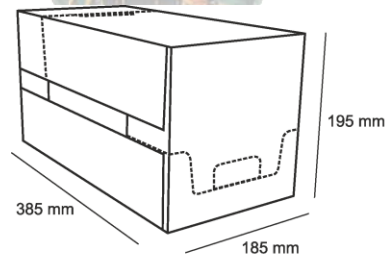

BABY FOOD:

- 15G / 8 CU
- 35G / 6 CU
- 70G / 12 CU
- 90G / 12 CU

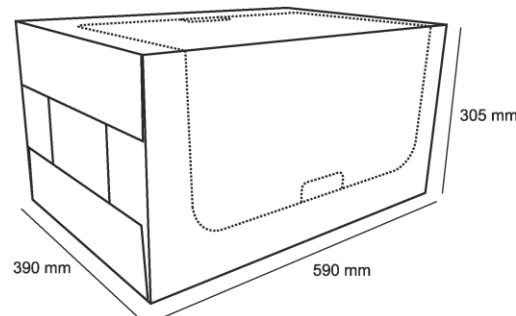
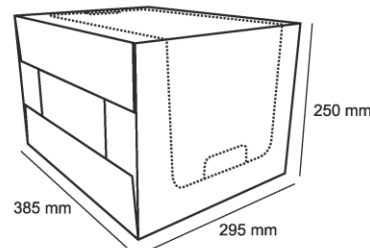

PACKAGING MATERIAL OPTIONS

- We are able to use EGP printing in most of our packaging materials.
- EGP (Expanded Gamut Printing) means more environmentally friendly way to print:
 - less material waste
 - less printing ink
 - less energy used
 - more efficient printing process etc.

PACKAGE SOLUTIONS:
FLOW PACK BAG

	Potato chips	Oat snacks	Pellet snacks	Corn snacks
PAP + MET OPP: can be recycled as fiber	x	x	x	x
PAP + OPP: can be recycled as fiber				x
OPP MET can be recycled as plastic	x	x	x	x
OPP can be recycled as plastic can include transparent areas				x

- Greener Printing logo can be placed to the package if EGP is used:



OWNERSHIP

Fodelia Retail is a subsidiary of Fodelia Oyj, who are on a mission to grow Finnish companies in the food industry, such as Oatis, into international success stories. All of Fodelias subsidiaries are united in their goal to bring customers clean, locally sourced and sustainably produced food.



Fodelia is a publicly quoted company, listed on the Nasdaq First North.



OIKIA PARTNERSHIP PAYS OFF

Oikia would not exist without partnerships and we are not afraid to show it. Our raw materials come from contract farmers and for this reason we can show the source of the potatoes and oat used in the production on each package. We don't shy away from showing off our companions, the fruit of our labour and what we have achieved together.

As co-operation is our second nature, we are always open to new, fruitful partnerships. Right now is the perfect time to get in contact with us, so we can start talking about our future together.



Oikia